

UM/C 2001. L.M.S./B.R. ROOF CONVERSION KIT.

For use with: GRAHAM FARISH SUBURBAN COACHES.

**INTRODUCTION.** This conversion kit is designed to improve the appearance of the C.F. suburban coaches by replacing the roof and adding torpedo ventilators giving close resemblance to Period 2 L.M.S. suburban coaching stock.

**ACKNOWLEDGEMENT.** The original idea for this conversion was that of Taylor Plastic Models. The Bullied roof now forms the basis of several conversion kits of which the L.M.S./ B.R. is the first, with others to follow.

**CONTENTS.** 1-off Bullied Roof. 20-off Torpedo ventilators.

**CONVERSION PROCEDURE.** Carefully separate the roof from the sprue, clean the sprue points with a smooth file, and cut to a length of 121mm which will allow an 'extra overhang' which should be filed down to give just 0.25mm overhang at each end of the coach body. File off the side location lugs to avoid fouling the inside of the coach body.

**NEXT,** cut out the roof template, stick it centrally to the plastic roof, and use the template to mark and drill 1mm holes (the use of a hand-held pin chuck is recommended) for fitting the torpedo ventilators. REMOVE the outer pair of rainstrips and the destination board brackets with Wet and Dry paper. REMOVE the template and glue the ventilators into place with liquid cement applied on the **UNDERSIDE.**

**BEFORE** fitting the roof reduce the height of the sides of the coach to 13.25mm by filing.(use the Farish roof as a 'support' in this operation). THEN re-profile the Farish coach ends to accept the NEW roof and fill in the resulting small gap with Plastikard which, itself, should be filed until the fit is perfect. If the roof is to be permanently fixed then the use of White (fine) Milliput putty is recommended for filling the gap.

**NOTE.** If a recent Farish coach is under conversion the Bullied roof can be made removable by transferring the OLD roof location point enabling the NEW roof to be clipped into place on the spigot. There is no such facility on earlier Farish models and permanent fixing is advised. In EITHER case Plastikard side location lugs should be added to the new roof. REMEMBER to place the glazing in place before fixing.

**FINAL DETAIL.** Please refer to the diagrams. There is only one battery box on the Third Class coach and the Brake Third. In the latter case it is situated on the side facing you when the Brake end is to the left. REMOVE two of the four V hangers as shown in the diagram.

**PAINTING.** Coach ends should be in BLACK and the Roof in GREY, although the roof was more of a 'dirty black' when in service.

**REFERENCES.** L.M.S Coaches by Jenkinson & Essery. Published by OPC.  
Historic Carriage Drawings in 4mm scale by Jenkinson and Campling. Published by Ian Allan.

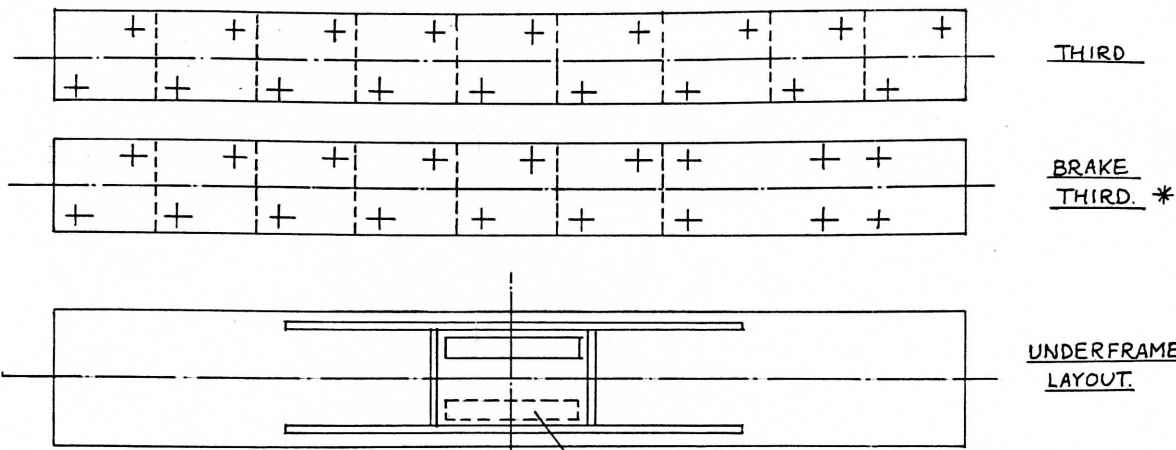

\* ALSO AVAILABLE CAST END UM/P616 PUSH-PULL TRAILER (DRIVER).

REMOVE 2<sup>ND</sup> B. BOX.

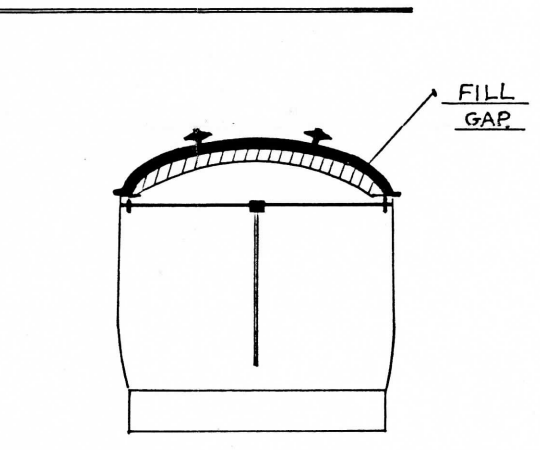
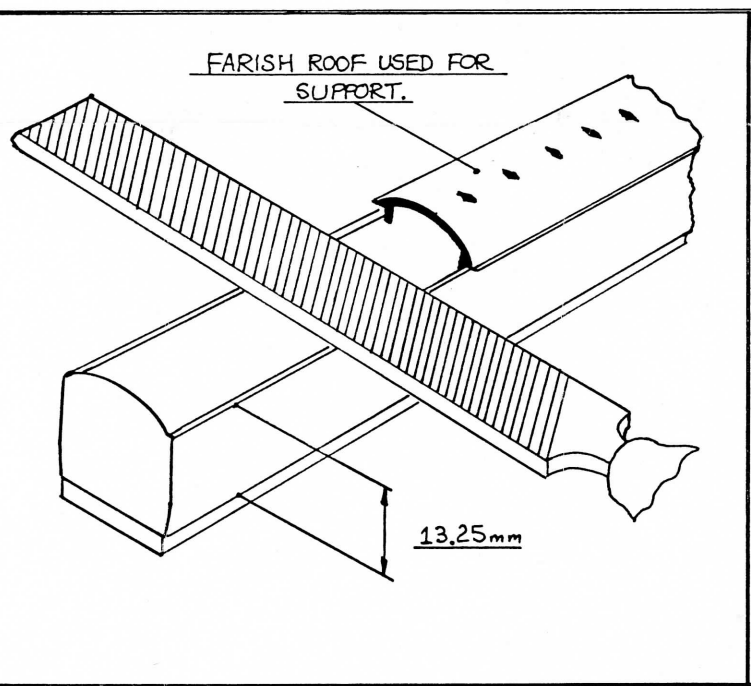
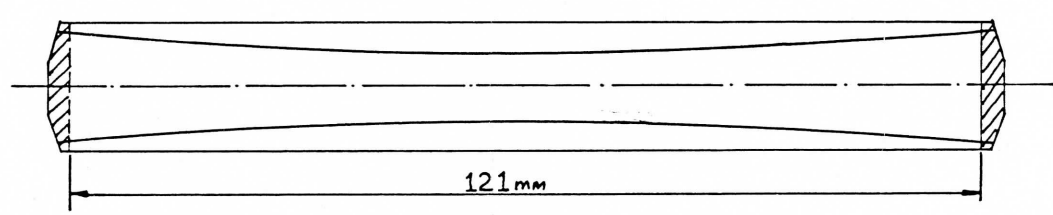

"THE GAP CAN ALMOST BE ELIMINATED IF CARE IS TAKEN WHEN FILING THE NEW ROOF TO MATCH THE ENDS."

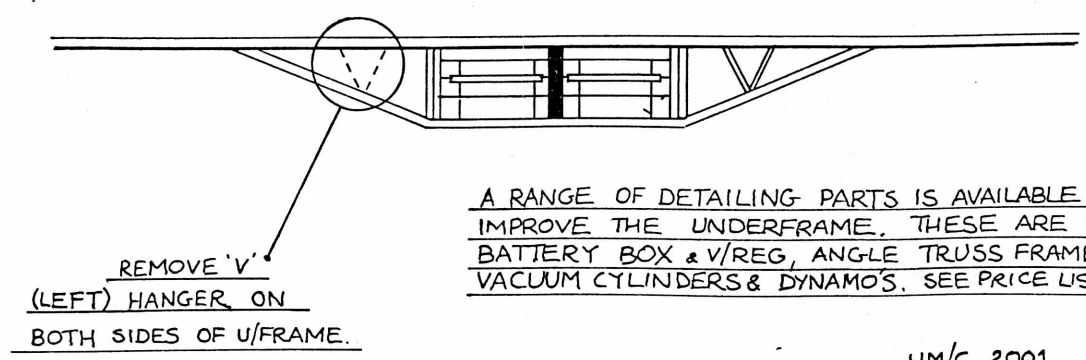

A RANGE OF DETAILING PARTS IS AVAILABLE TO IMPROVE THE UNDERFRAME. THESE ARE 8' BATTERY BOX & V/REG, ANGLE TRUSS FRAMES, VACUUM CYLINDERS & DYNAMO'S. SEE PRICE LIST.